

## Auxiliary Coil 1000645

### Instruction sheet

10/15 ALF



- 1 Coil
- 2 4-mm-sockets

### 1. Description

The auxiliary is used to create a magnetic field perpendicular to the axis of a tube. When used in conjunction with the Helmholtz pair of coils D and S (1000644 and 1000611) and the Perrin tube D and S (1000650 and 1000616) two orthogonal magnetic fields can thus be generated at right angles to the tube axis to demonstrate the basic principles of a cathode ray oscilloscope.

The air filled coil is made of lacquered copper wire on a plastic bobbin with a lip for securing to the fork of the tube holder D (1008507). Connections are labelled from the start (A) to the end (Z) of the coil winding.

### 2. Technical data

Number of windings:	1000
Maximum current:	2 A (short term)
Effective resistance:	7 $\Omega$ approx.
Connection:	via 4-mm sockets

### 3. Operation

#### 3.1 Set-up of the auxiliary coil on the tube holder D (1008507)

- Insert a hot cathode tube into the tube holder D.
- Place the coil on the upper fork of the tube holder (refer to Fig.1).
- Push the retaining slider over the lip of the auxiliary coil to secure the coil in place.

#### 3.2 Set-up of the auxiliary coil on the tube holder S (1014525)

- Connect up the coil using experiment leads.
- Place the coil on the ramp of the tube holder S so the plugs slide into the corresponding slot (refer to Fig.2).
- The leads may be trailed through the mouth of the ramp.
- Insert a hot cathode tube into the holder.

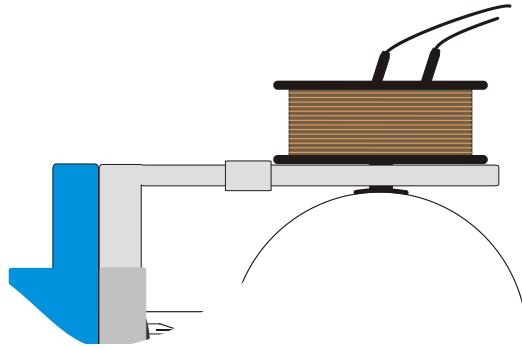

Fig. 1 Set-up of the auxiliary coil on tube holder D (1008507)

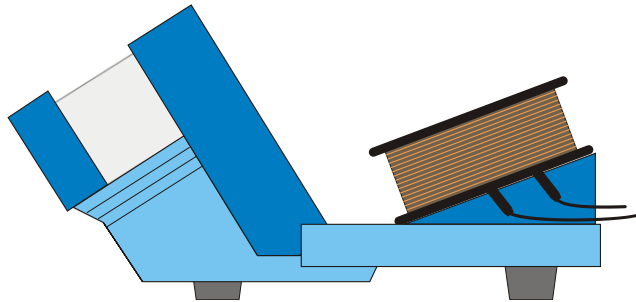

Fig. 2 Set-up of the auxiliary coil on tube holder S (1014525)