

High-Pressure Mercury Vapour Lamp 1000852

Instruction sheet

09/15 THL/ALF

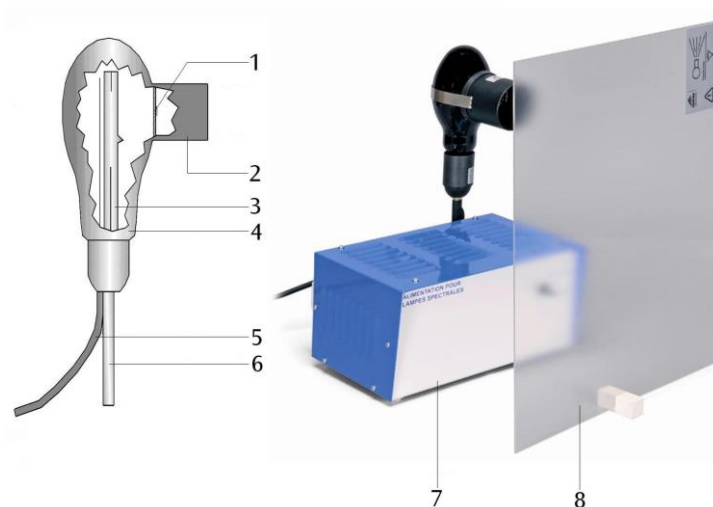

- 1 Window with wire mesh screen
- 2 Tube
- 3 Mercury arc
- 4 Glass bulb
- 5 Connection cable with multi-pin plug
- 6 Stem with E27 lamp socket
- 7 Power supply unit (not included)
- 8 Protective screen

1. Safety instructions

The high-pressure mercury vapour lamp emits ultra-violet light in the UV-A, UV-B and UV-C regions. However, the intensity of the radiation is so low that, as long as the lamp is used properly, it presents no risks to those conducting the experiments or any observers.

If there is reason to suspect that the lamp can no longer be used safely (e.g., if any glass part is damaged), it must be taken out of service immediately.

- Only operate the high-pressure mercury vapour lamp with the recommended power supply unit.

The high-pressure mercury vapour lamp is made of glass and contains mercury. Therefore there is a risk of breakage.

- Handle the lamp carefully and do not subject it to any mechanical stress.
- If the quartz tube is broken, clean up the mercury according to the correct procedure to prevent the escape of toxic mercury vapour.
- If it becomes necessary to dispose of the high-pressure mercury vapour lamp, local

regulations for such disposal must be observed.

UV radiation is damaging to the retina.

- Do not look into the direct light beam or a reflected beam.
- Always position the safety screen between any observers and the high-pressure mercury vapour lamp.
- Switch off the lamp before changing the experiment set-up.

During operation the body of the lamp will get hot so that there is a risk of getting burned.

- Do not touch the body of the lamp after switching on.
- After the experiment, leave the high-pressure mercury vapour lamp to cool.
- Do not operate the high-pressure mercury vapour lamp continuously for longer than 10 minutes.
- Allow a break of at least 10 minutes between successive periods of operation.

Ozone is generated during the operation of the high-pressure mercury vapour lamp.

- Ensure that there is adequate ventilation during the experiment.

2. Description

The high-pressure mercury vapour lamp serves as a light source that emits light with a very high ultra-violet content.

It consists of a mercury arc (a quartz arc tube with sealed-in electrodes and containing mercury) within a bulb of hard blackened glass that has a tubular opening. A wire mesh screen inside the tube serves to protect the mercury arc and provides protection in case the glass shatters. The lamp is mounted on a stem with an E27 lamp socket.

A transparent screen serves to protect the observer from UV radiation. It is made of a special plastic that absorbs almost all radiation throughout the UV spectrum.

3. Equipment supplied

- 1 High-pressure mercury vapour lamp
- 1 Protective screen

4. Technical data

Power consumption:	125 W
Power supply:	Power should only be provided via the control unit for spectral lamps (230 V or 115 V)
Wavelength range:	UV-A, UV-B, UV-C
Colour temperature:	4200 K

5. Operation

To carry out the experiments, the following equipment is also needed:

Control Unit for Spectral Lamps @230 V
1003196

or

Control Unit for Spectral Lamps @115 V
1003195

- Set up the experiment in such a way that the observers are standing at right angles to the direction of the light beam.
- Set up the protective screen directly beside the lamp so that the observers are protected from light that is radiated sideways from the lamp.
- After the experiment, allow the high-pressure mercury vapour lamp to cool.
- Do not operate the high-pressure mercury vapour lamp continuously for longer than 10 minutes.
- Allow a break of at least 10 minutes between successive periods of operation, as a lamp that is still warm after operation will not work if switched on again. If necessary, accelerate the cooling by blowing on the apparatus.

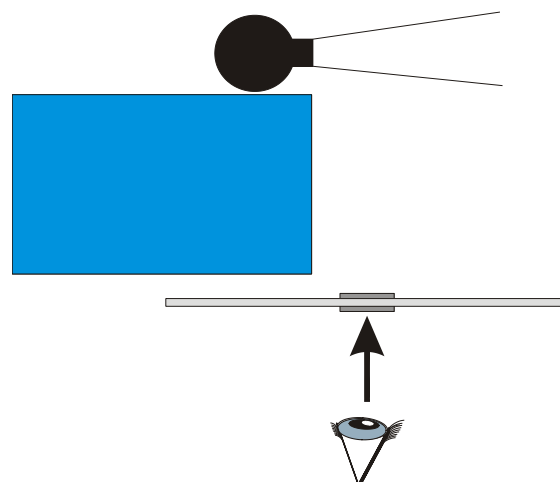

Fig. 1 Positioning of the protective screen in relation to the high-pressure mercury vapour lamp (view from above)