

Microwave Set 9.4 GHz (230 V, 50/60 Hz) Microwave Set 10.5 GHz (115 V, 50/60 Hz)

1009950 (115 V, 50/60 Hz)
1009951 (230 V, 50/60 Hz)

Instruction sheet

09/17 ERL/ALF

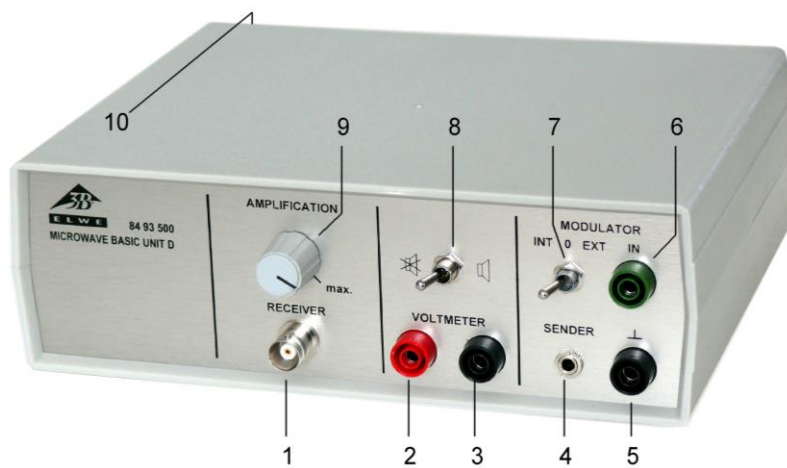

Control unit

- 1 Receiver terminal
- 2 Amplifier output
- 3 Amplifier output (ground)
- 4 Transmitter terminal
- 5 Modulation input (ground)
- 6 Modulation input
- 7 Modulator selector switch (internal/off/external),
- 8 Switch for internal speaker
- 9 Controller for receiver signal amplification
- 10 Socket for 12-V AC plug-in power supply (rear of case)

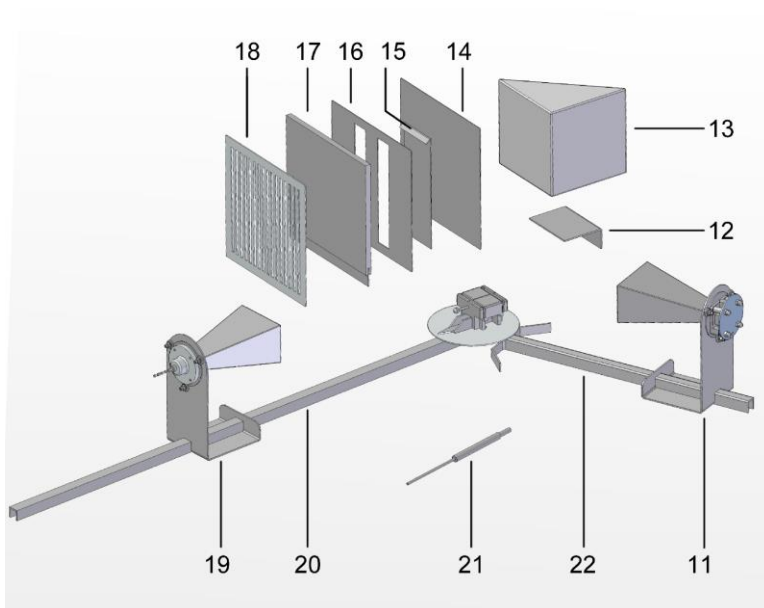

Accessories

- 11 Transmitter with horn antenna
- 12 Stand for prism
- 13 Paraffin prism
- 14 Reflection plate
- 15 Cover plate for double slit
- 16 Plate with double slit
- 17 Absorption plate
- 18 Polarisation grating
- 19 Receiver with horn antenna
- 20 Microwave bench
- 21 Microwave probe
- 22 Folding microwave bench with plate holder

1. Safety instructions

High frequency radio waves can penetrate biological tissues and cause them to heat up. The microwave transmitter included here is sufficiently low-powered that the hazards are negligible when it is used correctly.

Safe operation of the equipment is guaranteed, provided it is used correctly. However, there is no guarantee of safety if the equipment is used in an improper or careless manner.

- Before setting up or starting any experiments, check the housing and mains lead for any damage.
- If it is deemed that the equipment can no longer be operated without risk (e.g. visible damage has occurred), the equipment should be switched off immediately and secured against any inadvertent use.
- The transmitter is only permitted to be connected to 3B-ELWE control unit.
- In schools and educational establishments, the equipment may only be operated under the supervision of trained personnel.
- Avoid looking directly into the antenna horn of the transmitter or the reflected beam.
- Only trained electricians are permitted to open up the apparatus' housing.

2. Description

This apparatus allows microwaves to be transmitted and received.

The components and equipment included allow for various experiments to be performed. These can achieve both qualitative and quantitative results.

A narrow beam of electro-magnetic waves with wavelength in the cm range can be output by a transmitter and picked up using the horn antenna (19) or the sensor probe (21). The modulation of the receiver signal can be rendered audible by means of an internal speaker, in which case the loudness of the acoustic signal varies with the intensity of the received signal.

The microwave apparatus is powered via a 12-V AC plug-in power supply.

The microwave apparatus 10.5 GHz (1009950) is for operation with a mains voltage of 115 V ($\pm 10\%$), and the microwave apparatus 9.4 GHz (1009951) is for operation with a mains voltage of 230 V ($\pm 10\%$).

3. Contents

- 1 Control unit
- 1 Transmitter with horn antenna
- 1 Receiver with horn antenna
- 1 Microwave probe
- 1 Microwave bench, 800 mm
- 1 Microwave bench, 400 mm with plate holder

- 1 Reflection plate 180 x 180 mm²
- 1 Polarisation grating, 180 x 180 mm²
- 1 Absorption plate, fibreboard, 180 x 180 mm²
- 1 Paraffin prism
- 1 Stand for prism
- 1 Plate with double slit
- 1 Cover plate for double slit
- 1 Instruction sheet

4. Technical data

Transmitter with horn antenna:

Frequency of oscillator:	9.4 GHz (1009951) 10.5 GHz (1009950)
Transmitted power:	10 mW to 25 mW
Modulation type:	AM
Modulation signal:	Selector switch Internal/off/external
Internal modulation:	3kHz approx. 80% AM approx.
External modulation:	100 Hz to 20 kHz, max. 1 V
Acoustic signal:	internal (switchable)
Output voltage:	10 V max.
Receiver with horn antenna:	Silicon diode with resonator
Microwave probe:	Silicon diode with resonator
Supply voltage:	12 V AC via plug-in supply
Dimensions (control unit):	170 x 200 x 75 mm ³

5. Operation

5.1 Set-up of base rails (basic set-up)

- Insert the central screw under the scale disc in the hole in the long rail.

The default set-up is with the rails opened out in a line (the arrow on the long rail points to "0°" on the protractor scale).

- Move the articulated base so that the pointer coincides with the zero point of the scale.

The pointer is aligned with the normal of the screen holder and thus allows the angle of incidence to be read off or adjusted directly (read off the outer numeric scale).

5.2 System set-up

- Connect to the mains.
- Connect the receiver with horn antenna or the microwave probe to the receiver terminal (1).
- Connect the transmitter with horn antenna to the transmitter terminal (4).
- Set up the transmitter and receiver on the base rails as appropriate to the experiment.

- Set the controller for the signal gain of the speaker (9) to its centre position.
- Use the switch (8) to turn on the speaker.
- Use switch (7) to send the modulator to “INT”.

The microwave signal emitted is modulated with a square wave. The modulation frequency can be listened to by means of the built-in speaker.

The amplified receiver signal can be output from sockets (2) and (3) in the form of a DC signal (once modulation has been turned off), in the form of a square wave (with internal modulation) or in the form of low frequency signal (external modulation).

Modulation is deactivated when switch (7) is in its centre position. DC signals proportional to the level and gain are output from sockets (3) and (4).

This can, for example, be displayed using an instrument with a dial (e.g. Escola 30 analog multimeter 1013526).

If switch (7) is set to “EXT” low frequency signals (e.g. from an MP3 player) can be input to sockets (5) and (6) and played on the internal speaker inside the basic apparatus. (jack to 4-mm socket adapter needed).

Information is sent via the microwave signal from the transmitter to the receiver.

6. Sample experiments

6.1 Straight-line propagation of microwaves

- Set up the transmitter (11) and receiver (19) facing one another.
- With the receiver off the rail, move it in a plane perpendicular to the rail.

The optimum reception is when the horns are directly facing one another.

Conclusion: microwaves propagate in a straight line (in uniform media or in a vacuum).

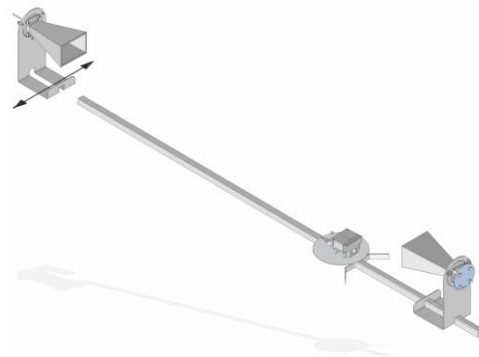

6.2 Penetration

- Attach the dry absorption plate (14) (electrical insulator) to the plate holder between the transmitter and receiver.
- Set the amplification (9) to a medium level.

Conclusion: microwaves can penetrate insulators, as demonstrated by the reception of a signal.

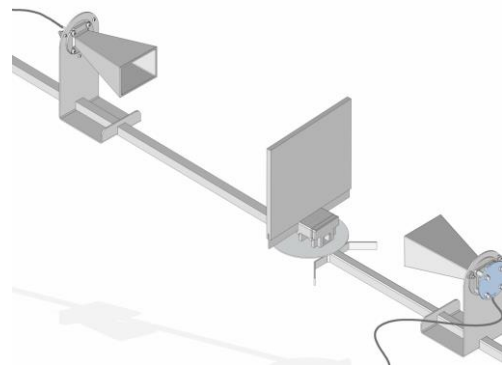

6.3 Screening and absorption

- Place the reflection plate (14) (electrical conductor) between the transmitter and receiver.
- Set the amplification to a low level.

Conclusion: electrical conductors can screen out microwaves (metal plates), as demonstrated by the fact that no signal is received.

- Attach the absorption plate to the plate holder having dampened both sides first.

Conclusion: When penetrating materials of low conductivity, the microwaves are attenuated, i.e. partially absorbed.

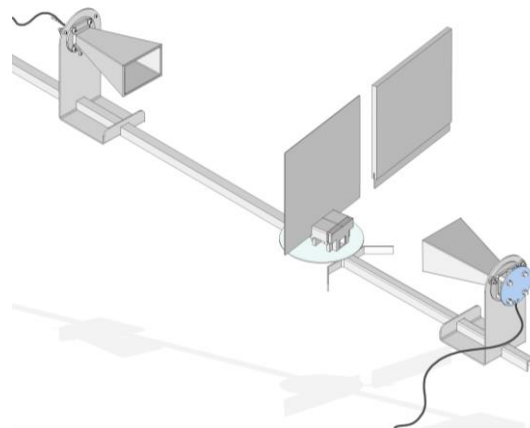

6.4 Reflection

- Set up the basic configuration (5.1).
- Line up the reflector plate at angles of approximately 30°, 40°, 50° and 60° with the help of the pointer for the rails, which points in the direction of the normal (a line perpendicular to the mirror's surface).
- Change the angle of the long rail until the maximum reception is attained.
- Measure angles of incidence from the normal (arrow).

Conclusion: an electrical conductor reflects microwaves. This confirms the law of reflection.

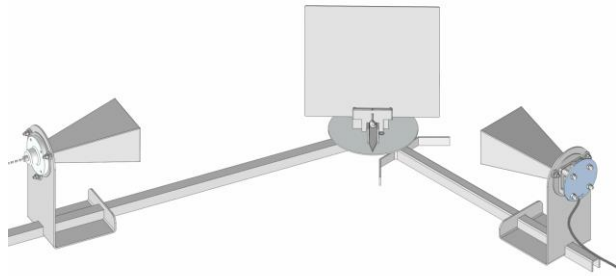

6.5 Determining wavelength of standing waves

- Set up the transmitter and reflector plate facing each other about 50 cm apart (angle of incidence 0°).

The transmitted and reflected waves are superimposed, resulting in a standing wave.

- Using the microwave probe (21) (with the marking on the special probe facing upwards) determine the distance a between two adjacent minima (this corresponds to half the wavelength).
- Calculate the frequency $f = c/\lambda$ from the wavelength λ of the microwaves.

$$\text{Results: } a = \frac{\lambda}{2} \approx 1,6 \text{ cm}, \quad f \approx 9,4 \text{ GHz}$$

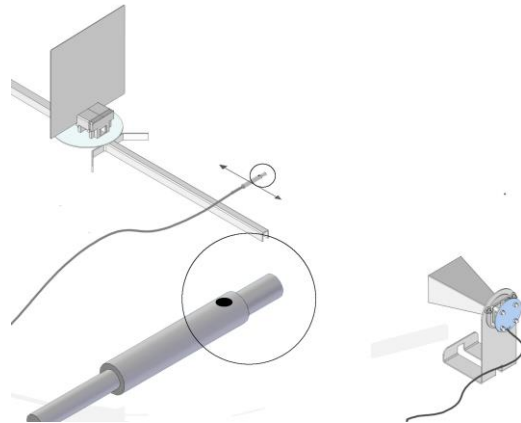

6.6 Refraction

- Set up the basic configuration (5.1).
- Insert the stand provided for the prism (12) into the side facing away from the arrow.
- Put the prism (13) onto the stand and line it up.
- Turn the long rail until the maximum reception is attained.

Conclusion: microwaves penetrate paraffin. As the waves pass from air to paraffin and from paraffin to air, the speed of propagation is altered and thus so is the direction (refraction).

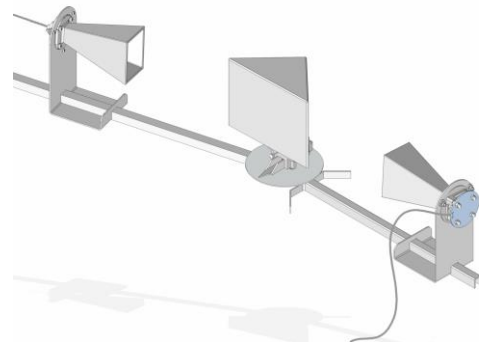

6.7 Huygens' principle

- Set up the transmitter (11) about 20 cm from the plate holder and the receiver (19) about 80 cm behind the plate holder on the rails.
- Turn the receiver around on its rail so that it is out of the bundled microwave beam and the signal is clearly weakened.
- Insert a single slit aperture into the plate holder and secure it gently in place (line up the centre of the slit in the centre of the plate).

Conclusion: microwaves are diffracted by the slit and wavelets can be detected beyond the plate (the modulation signal is audibly louder).

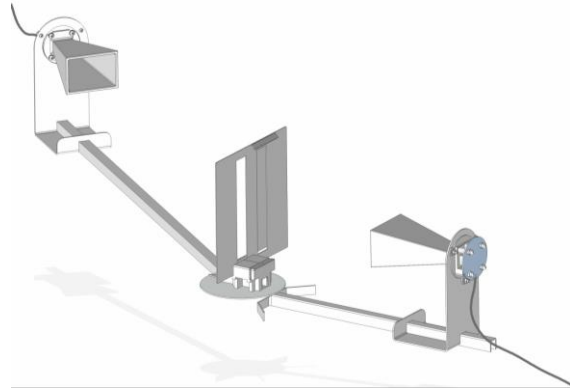

6.8 Diffraction

- Clamp the cover plate (15) in the holder on the hinge plate.
- Set up the transmitter about 20 cm in front of the plate.
- Move the probe (21) in a horizontal plane behind the plate.

Conclusion: even when the probe is in the shadow of the plate, it can still pick up signals due to diffraction.

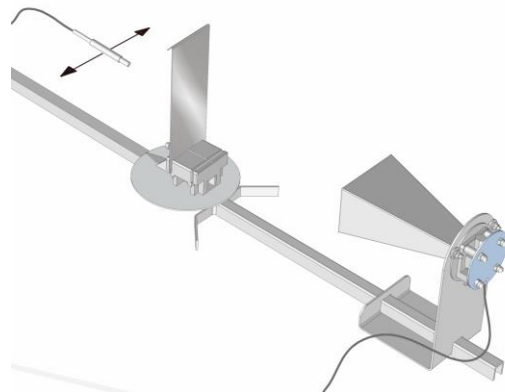

6.9 Interference

- Clamp the plate with the double slit (16) centrally in the holder on the plate over the hinge.
- Position the transmitter about 12 cm in front of the plate.
- Move the receiver probe parallel to the plate with the double slit about 6 cm behind it.

Conclusion: Since the number of maxima is larger than the number of slits, this demonstrates the presence of interference.

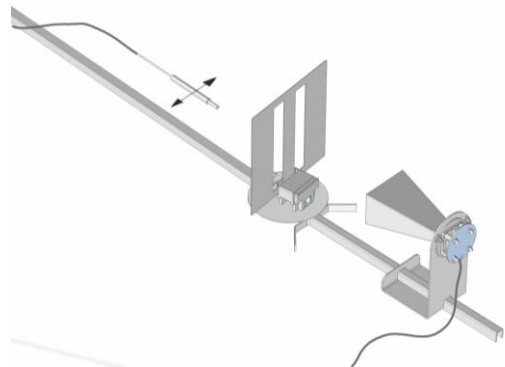

6.10 Polarisation

- Set up the polarisation grating (18) in the screen holder.
- Check the reception when the polarisation grating is aligned horizontally.
- Check the reception when the polarisation grating is aligned vertically.

Conclusion: Since in one state a signal is received but when the grating is rotated 90° no signal reaches the receiver, it can be demonstrated that the horn antenna produces a field that oscillates in one direction only, i.e. the output is polarised.

The experiment proves that the waves are transverse.

If the transmitter and receiver are set up so that one is vertical and one horizontal, no reception is possible

If the polarisation grating introduced into the beam and tilted by 45°, an attenuated signal is received. The polarising plane is thus inclined.

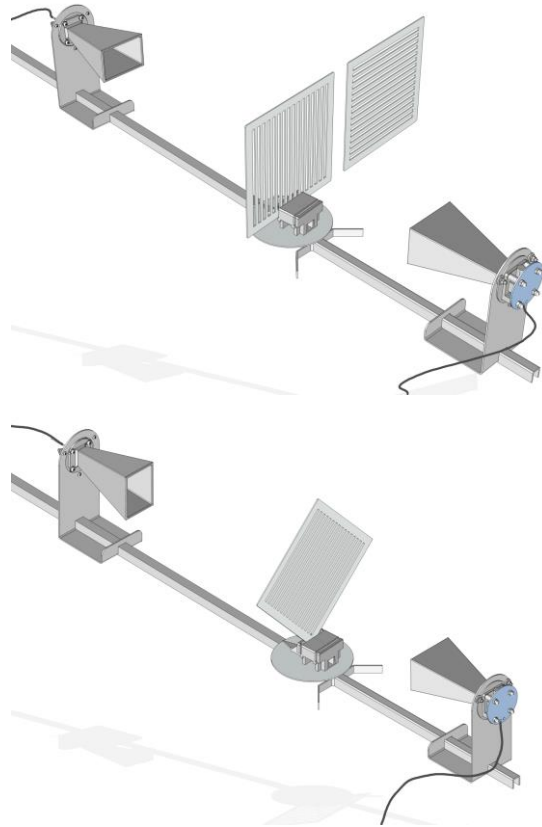

6.11 Transmission of information

- Set up the transmitter and receiver facing one another.
- With the receiver off the rail, move it in a plane perpendicular to the rail.
- Reception is best when the openings are facing one another.

Using internal modulation (3 kHz signal) or external modulation (e.g. sound from an MP3 player) it is possible to transmit information.

Conclusion: microwaves (electro-magnetic waves) can carry information.

