

Electric Field Meter U8533015

Instruction Sheet

02/08 ALF

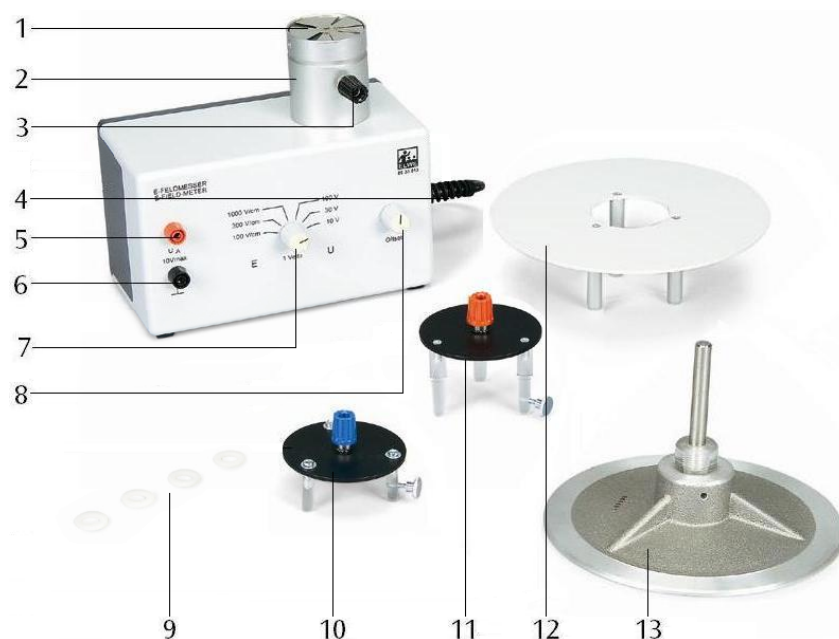

- 1 Shielding plate
- 2 Screening cylinder
- 3 Earth socket
- 4 Mains switch (not visible)
- 5 Output voltage socket
- 6 Earth socket for output
- 7 Measurement range switch
- 8 Offset adjustment
- 9 Set of Plexiglas spacer discs
- 10 Voltage measurement plate for 1× range
- 11 Voltage measurement plate for 10× range
- 12 Capacitor plate for voltage measurements, 250 cm²
- 13 Capacitor plate, 250 cm²

1. Safety Instructions

The electric field meter complies with the safety requirements of DIN EN 61010, part 1, relating to electrical measurement, control and regulation applications and for laboratory instruments, and its design complies with protection class I. It is designed for operation in dry environments suitable for working electricity.

Safety is guaranteed if the instrument is used as stipulated. However, safety cannot be guaranteed in cases of incorrect or careless operation.

If there is reason to suspect that safe operation is no longer assured, the instrument must be taken out of use immediately.

In schools and other educational establishments, the instrument may only be used under the supervision of a responsible person.

- Before using the instrument for the first time, check that the local mains voltage corresponds with that printed on the back of the housing.
- Before using the instrument, examine the housing and the mains cable. If there is visible damage or if the instrument does not function properly, take it out of service and secure it to prevent unauthorised use.
- The instrument may only be plugged in at a mains socket with an earth connection.
- The capacitor plate and the voltage measurement plate must only be put in place when the instrument is switched off.

2. Description

The electric field meter is used for the measurement of electrostatic field intensities or voltages.

1. The principle for measuring electric field strength is as follows: A shielding plate with four vanes distributed in the shape of a star (induction plate) is rotated in front of a detector plate (probe) of similar shape. This arrangement means that the electric flux surrounding the detector plate is continually interrupted, so that an induced charge is generated intermittently on the detector plate. This periodically occurring charge is conducted away through a high-value resistor. The voltage pulses thus generated are amplified and rectified. The resulting output voltage is proportional to the induced voltage, and therefore to the strength of the electric field acting on the detector plate.

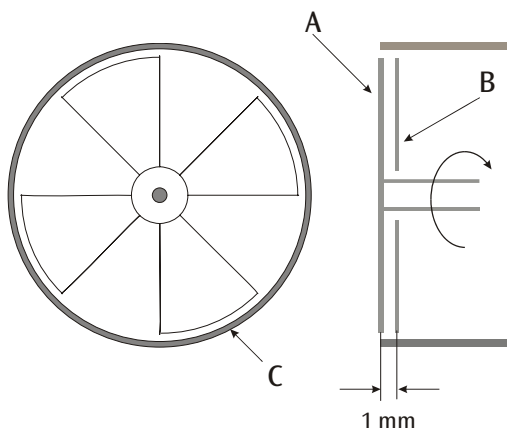

Fig. 1 A Shielding plate, B Induction plate, C Screening cylinder

An ordinary DC voltmeter (with measurement ranges 1 V and 3 V) can be used to display the results. The 1V range corresponds to electric field strength ranges of 100 V/cm, 300 V/cm or 1000 V/cm, selected by turning the rotary selector switch knob to one of the three “E” positions.

2. The principle of the electric field meter when used as an induction electrometer is as follows: A capacitor plate (the voltage measurement plate) is positioned at a precisely defined distance from the detector plate (probe). The combination of the two forms a capacitor, and the electric field strength within it is a function of the capacitor voltage and the distance between the plates.

With the range switch set to one of the “U” positions, a voltage applied to the voltage measurement plate is indicated on the voltmeter. When the voltage measurement plate is positioned at the shorter of the two distances, a meter reading of 1 volt corresponds to a measured voltage of 10 V, 30 V or 100 V, depending on the position of the switch in the “U” range. When the voltage measurement plate is positioned at the greater distance, the measurement ranges are increased by a factor 10.

The instrument is fully protected against excess voltage, even if a spark discharge occurs.

3. Equipment Supplied

- 1 Electric field meter, basic instrument
- 1 Voltage measurement plate for measurement range 1×
- 1 Voltage measurement plate for measurement range 10×
- 1 Capacitor plate for voltage measurements, 250 cm²
- 1 Capacitor plate on stem, 250 cm²
- 20 Plexiglas spacer discs, 1 mm

4. Technical Data

Operating mains voltage: see back of instrument

Output voltage: max. 10 V

Measurement ranges (corresponding to 1V output):
 100 V/cm, 300 V/cm,
 1000 V/cm
 10 V, 30 V, 100 V (with voltage measurement plate 1x)
 100 V, 300 V, 1000 V (with voltage measurement plate 10x)

Input resistance: 10 MΩ

Dimensions: 140×110×70 mm³ approx.

Weight: 1 kg approx.

The U8533015-230 electric field meter is designed for a mains voltage of 230V (±10%), and the U8533015-115 model for 115V (±10%).

5. Recommended Accessories

Analog multimeter AM50	U17450
Accessories for the electric field meter	U8533050
Contact rod	U8497730
Resistor 300 kΩ	U51013

6. Operation

6.1 General instructions

- Whenever possible, conduct the experiments using voltages that are not dangerous to the touch.
- When using mains-connected instruments that generate a voltage that would be dangerous to touch, use a resistor (U51013) to limit the current.
- For all measurements, connect the contact rod to the earth socket on the screening cylinder and hold it in your hand, so that you are also at the same potential.
- Before each set of measurements, the zero-point of the electric field meter should be calibrated for all the measurement ranges.

- After plugging into the mains, wait a few minutes for the instrument to reach normal working temperature.
- To avoid damage to the electric field meter, do not touch the rotating vaned wheel.
- The insulating parts of the instrument and the measurement plates must be kept clean and dry (avoid touching them). When the air is very humid, it may be necessary to dry them in a current of warm air (use a hair-dryer).

For measurements of electric field strength, the induction plate should be positioned below the screening plate. The difference Δd is approximately 1 mm, and for precise measurements it must be determined experimentally and taken into account in the measurements. The field strength E is calculated from the voltage U and the distance d between the plates according to the formula

$$E = \frac{U}{d + \Delta d}.$$

6.2 Zero-point calibration

- First calibrate the zero-point for the indicating instrument (e.g., a voltmeter – see relevant instruction sheet).
- Connect the indicating instrument to the voltage output of the electric field meter.
- Place the voltage measurement plate in position at the shorter distance and secure it with the knurled screw.
- Turn the measurement range switch to the “U” position and set to the highest range.
- Connect the measurement plate to the earth socket of the screening cylinder.
- Switch on the electric field meter and set the zero point using offset adjustment.
- Calibrate the zero-point for the two lower measurement ranges by the same procedure.

6.3 Measurement of the field strength in a plate capacitor

This experiment requires a DC power supply with a smoothed voltage output, for example:

1 DC power supply, 500 V	U33000-230
or	
1 DC power supply, 500 V	U33000-115
1 Resistor 300 k Ω	U51013
1 Contact rod	U8497730

- Set up the experiment as shown in Fig. 2.
- Connect the indicating instrument to the voltage output of the electric field meter.
- Place the capacitor plate for voltage measurements on the screening cylinder and secure it with the knurled screw.
- Place the required spacer discs on the capacitor

plate for voltage measurements and place the other capacitor plate on top.

- Connect the positive output terminal of the DC power supply to the upper capacitor plate and the negative output terminal to the earth socket of the screening cylinder.
- Turn the measurement range switch to the “E” position and select the required range.
- Switch on the electric field meter and the DC power supply.
- Make a connection between the person conducting the experiment and the earth socket of the screening cylinder.
- Carry out the measurement.
- Compare the measured field strength with the theoretical value.
- Make a series of similar measurements with different distances between the plates using the spacer discs, to demonstrate the dependence of the field strength on the plate separation.
- After the experiment, discharge the capacitor plate by connecting it to the screening cylinder.

6.4 Measurement of voltages using the instrument as an induction electrometer

Additional equipment required:

1 High voltage power supply, 5 kV	U33010-230
or	
1 High voltage power supply, 5 kV	U33010-115
1 Resistor 300 k Ω	U51013
1 Contact rod	U8497730

- Set up the experiment as shown in Fig. 3.
- Connect the indicating instrument to the voltage output of the electric field meter.
- Depending on the voltage to be measured, place the appropriate voltage measurement plate on the screening cylinder and secure it with the knurled screw.
- Connect the positive output terminal of the high voltage power supply to the voltage measurement plate and the negative output terminal to the earth socket of the screening cylinder.
- Turn the measurement range switch to the “U” position and select the required range.
- Switch on the electric field meter and the high voltage power supply.
- Make a connection between the experimenter and the earth socket of the screening cylinder.
- Carry out the measurement.
- After the experiment, discharge the voltage measurement plate by connecting it to the screening cylinder.

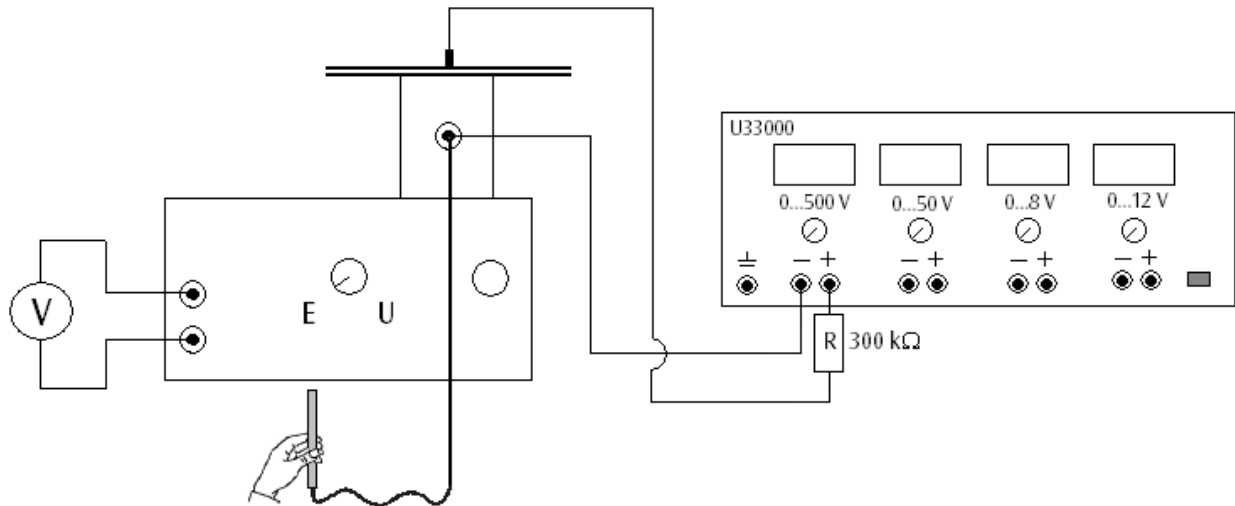

Fig. 2 Determining the field strength inside a plate capacitor

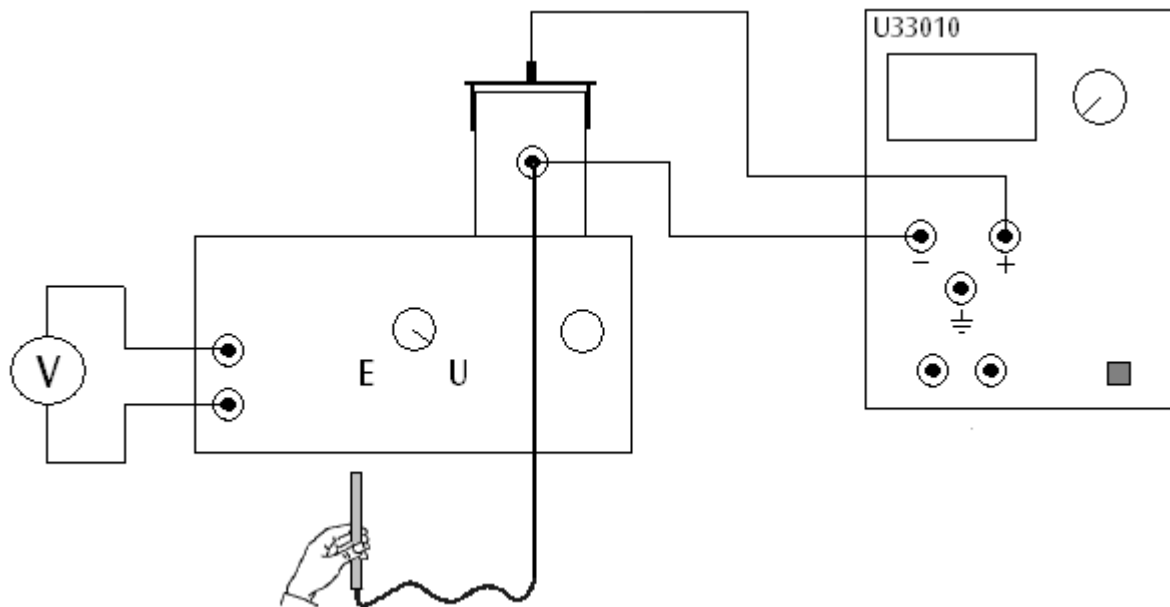

Fig. 3 Voltage measurement using the instrument as an induction electrometer